

PLASMA

*Automatic welding
in the boiler
maker industry.*

The plasma arc : a natural phenomenon tamed by SAF.

The term PLASMA applies to gases at temperatures exceeding 3000°C at atmospheric pressure. It can be regarded as the fourth state of matter, following the solid, liquid and gaseous states on the temperature scale. The PLASMA is made up of excited ions, electrons, atoms or molecules ; it occurs in nature, generated by lightning, for example. Since about 1960, and largely due to SAF, the word PLASMA has gained a new meaning, referring to the high-energy state caused

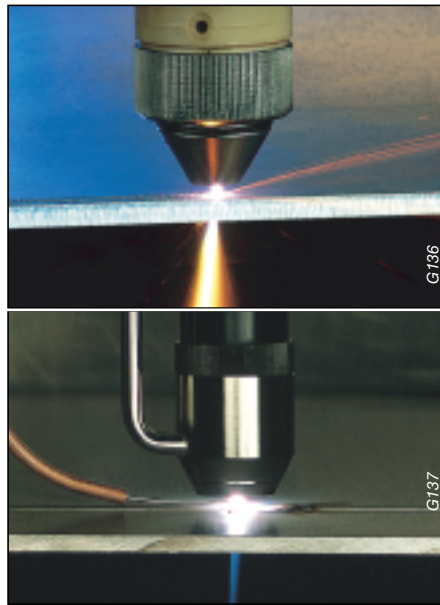

by constricting an electrical arc by means of a diaphragm or nozzle. This principle is now widely used in the steel, chemical and mechanical engineering industries. **As market leader in this sector, SAF has turned it into a powerful cutting and welding tool.** It is generally accepted that the PLASMA welding process is the major technological advance from inert gas shielded free arc welding (the TIG process).

Plasma arc : high temperatures, a concentrated beam, better productivity.

The isotherm diagram opposite shows clearly that the energy distribution is strongly modified within the PLASMA arc :

- the 16 000 K to 24 000 K temperature zone is outside the nozzle,
- the 10 000 K to 16 000 K temperature zone is entirely transferred to the workpiece and causes the "keyhole" effect (penetration of the workpiece).

With a FREE arc (TIG process) the highest temperature zone is too close to the cathode to be usable.

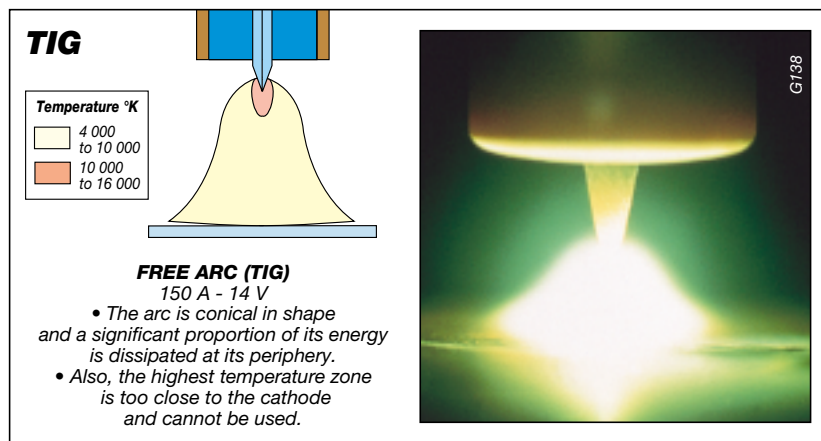

The 4 000 K to 10 000 K temperature zone is narrow in PLASMA welding and much more spread in TIG welding. This zone is helpfull in creating surface melting of decreasing depth relative to the plane of the joint, providing a gentle transition from the welded area to the basic metal. This zone is excessively wide in TIG welding, however, and it limits performance.

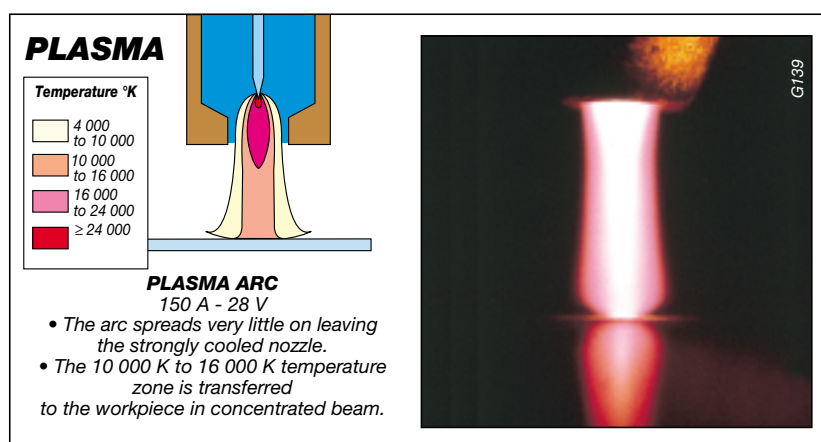

AUTOMATIC PLASMA WELDING

in the stainless steel boiler maker industry



Boiler makers manufacture weld assemblies of medium and large capacity from metal sheets and often the first operation consist of welding single sheets to obtain the evolution of shells or the shapes of the dish ends. Today, throughout the world, often this first operation is still carried out manually. To obtain the level of quality required but more important, the repeatability of the quality obtained, automation of the process must be envisaged.

*Acknowledgements :
we particularly wish to thank the following companies for the pictures' loan :
HOLVRIEKA, MIELI and TECHNIMETAL.*

WHAT MUST BE ACHIEVED ?

- **Rapidity of operation, low deformation** to avoid or reduce the reconforming post operations,
- **low reinforcement** to reduce or suppress polishing operations,
- **keep the original chemical analysis** of the base material to guarantee corrosion characteristics,
- **good visual aspect** of the welds since most of the welds are more and more visible. It is a quality criteria,
- **repeatability** of the quality obtained.

SAVINGS ?

The long experience of SAF in PLASMA welding associated with the high reliability of its equipment will guaranty you the lowest cost per meter weld. Compared to TIG (GTAW) and to stick electrode (SMAW), savings

can be achieved in labor and consumable costs due to improvement in welding time. This has enable most of our customers to reach returns on investment of between 1 and 2 years depending on work load.

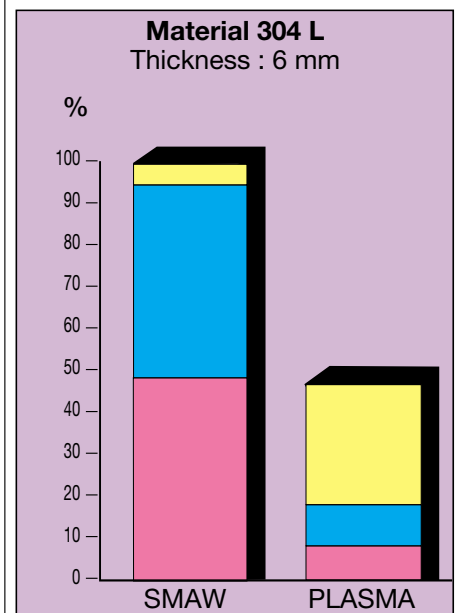
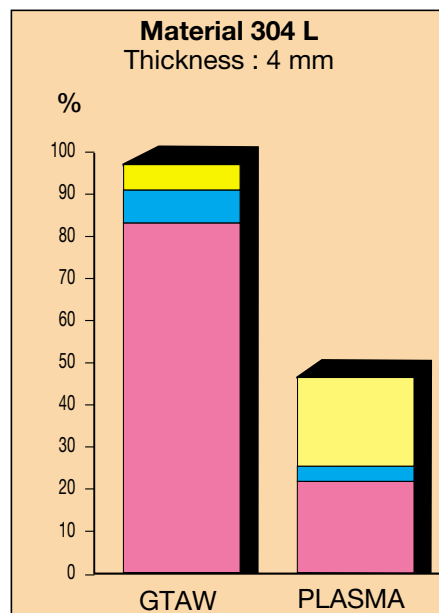

Investment
 Consumables
 Labor

ADVANTAGES OF THE AUTOMATIC PLASMA WELDING PROCESS

TOP QUALITY RESULTS AND INCREASED PRODUCTIVITY

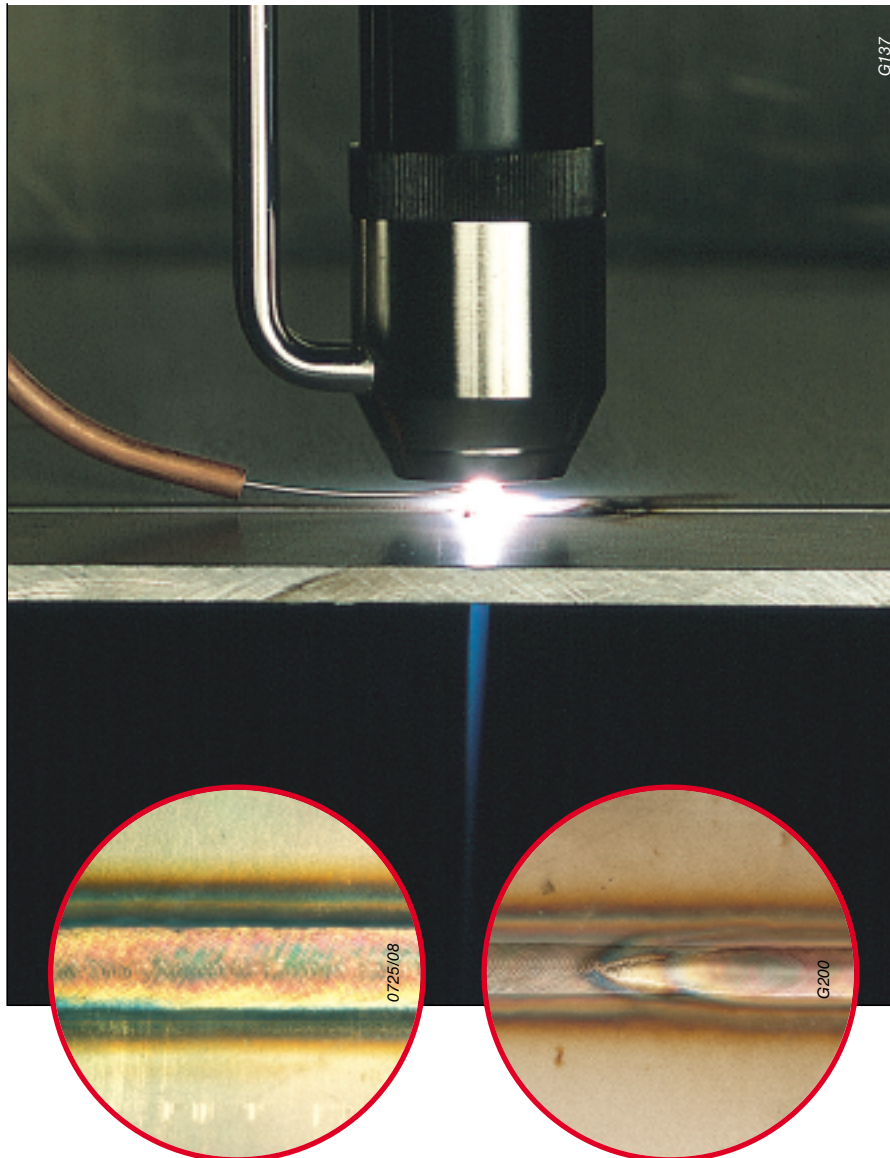

In the constant search for optimal productivity, every industry must strive to reduce production time while maintaining extremely high quality. In the case of plasma welding, unlike the trichode process, the multiplication of torches would have little effect on the performance levels.

Nevertheless, a solution exists for increasing speeds by 30 to 50 % in comparison with a single torch : PLASMA + TIG process.

Thanks to this technique, the PLASMA arc melts the joint throughout its thickness, while the TIG arc, equipped with a magnetic oscillation system and additional filler metal prepares the final appearance of the surface.

This yields results that are perfectly suited to the specifications of speed and quality. SAF, an innovative specialist in TIG and PLASMA welding, naturally offers installations combining these techniques, which are particularly suitable for production of large stainless steel vessels. Nonetheless, certain strict criteria are required for ensuring the profitability and the technical feasibility of these materials.



These criteria may be summed up as follows : manufacture of stainless steel tanks from 3 to 8 mm thick, with a welding length of at least three meters, or parts with a diameter greater than 2200 mm.

- Initial plate preparation/fit-up greatly reduced by suppression of bevel up to 7 mm.
- Reduction of welding times compared to manual welding (up to 4 to 5 times).
- A guaranteed regular penetration thanks to the «key hole» technique on all but joints with TIG pre-tacking.

- A very high quality weld in regard to most stringent controls. It eliminates hazards of lack of penetration at the beginning of welds as well as the systematic delicate repairs after grinding of beginnings and ends of welds.
- A guaranteed reproductibility, thanks to memorization* of complete welding parameters programs (simply defined by material, diameter and thickness).
- High quality finish on circular welds thanks to the automatic key hole closure system*.

Thickness (mm)	PLASMA	PLASMA + TIG
	Welding speed (cm/min.)	
3	50	65
4	35-40	50-60
6	25-30	40
8	15-20	25

(austenitic stainless steel)

* PLASMA with microprocessor installation only.

PLATE EDGE PREPARATIONS

Initial plate preparation/fit-up greatly reduced by suppression of bevel up to 7 mm.

This will in turn considerably reduce the amount of filler wire to be used.

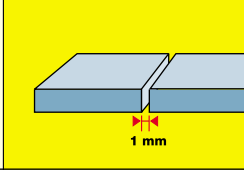
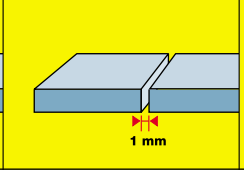
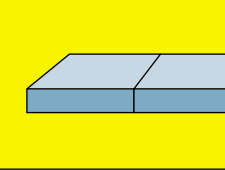
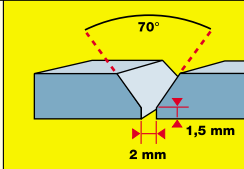
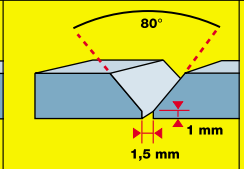
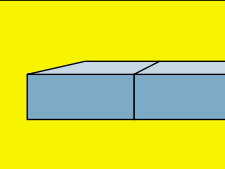
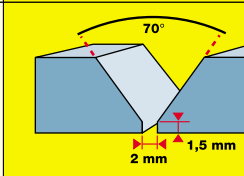
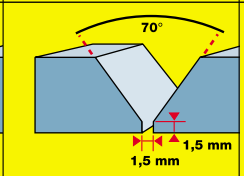
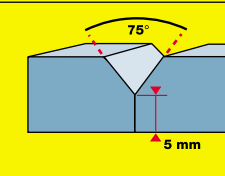
Thickness (mm)	Stick electrode (S.M.A.W)	Manual TIG (G.T.A.W.)	PLASMA (P.A.W.)
3			
6			
10			

ROOT PASS AND FILLER PASSES

ROOT PASS	Stick electrode (S.M.A.W)	Manual TIG (G.T.A.W.)	PLASMA (P.A.W.)
Plate preparation	chamfer + root face	chamfer + root face	2.5 - 8 mm : none then chamfer + root face
Fit-up	relatively difficult (gaps)	difficult (small gaps)	easy (no gap)
Welder skill required	highly skilled	highly skilled	semi-skilled / unskilled
Process Speed	very slow	very slow	quite fast
Level of difficulty over process	difficult	quite difficult	easy
Quality of result	good but appearance can be poor	good	excellent
Particular problems	electrode heating, quality control, distortion	very tiring for welder, quality, distortion	none

FILLER PASS	Stick electrode (S.M.A.W)	Manual TIG (G.T.A.W.)	PLASMA (P.A.W.)
Volume of filler required	high (small root face)	high (small root face)	low (small root face)
Process speed	very slow	very slow	quite slow
Welder skill required	average	average	average-slow
Level of difficulty	average	average	low
Quality of result	average	good	excellent
Particular problems	pre-heating of electrodes, interpass grinding. Frequent stop-starts (every minute) quality control more difficult	slow, laborious process, high heat input, distortion	none

WELDING CONFIGURATIONS

These configurations are the ones that are most commonly encountered when PLASMA welding of stainless steel shells.

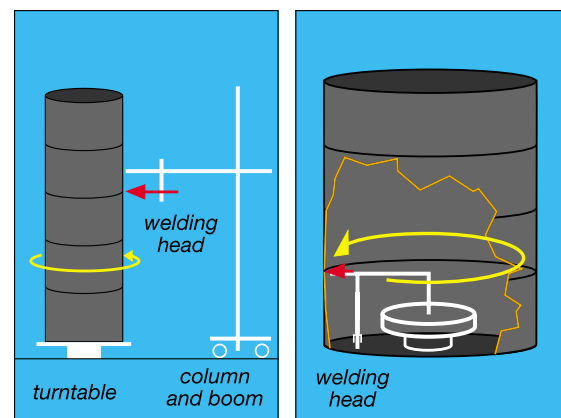
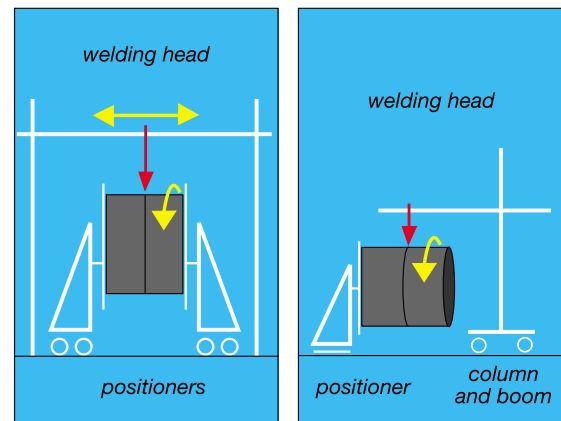
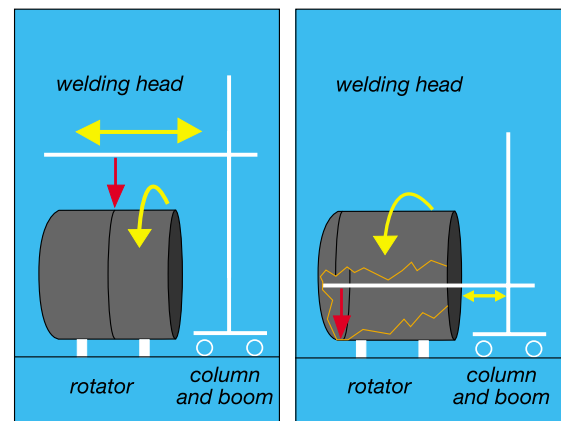
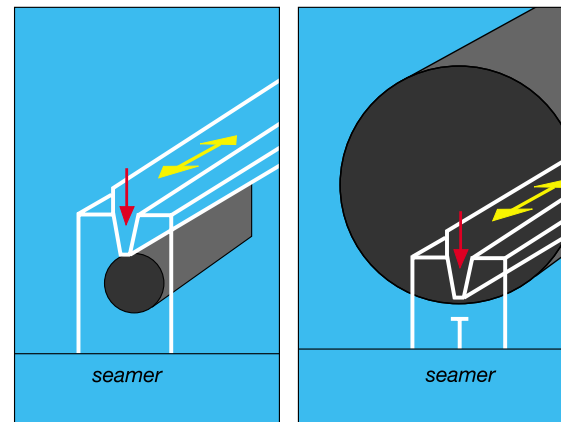

THE PLASMA WELDING INSTALLATION FOR THE BOILER MAKER INDUSTRY

Thanks to its characteristics and its high degree of automation which makes it relatively easy to master, the PLASMA process is now commonly used in the boiler making industry

and SAF since 1965, has installed more than 800 installations throughout the world. SAF offers now a wide range of turn key welding installations, but it has to be chosen carefully according to the work to be done.

It involves 3 levels of sub assemblies :

- the PLASMA welding equipment,
- the support structure of the PLASMA equipment,
- the positioning equipment to rotate the rounded sheets and/or the seamer bench.

THE WELDING EQUIPMENT

Max welding current (100 %)	Power source	Technology	Linear welding	Circular welding	Installations type	Offer ref. number
300 Amps	NERTAMATIC 300 TR	quick regulation transistor with 1 to 500 Hz pulsation	■ ■ ■ ■	* ■ ■ ■	SIMPLE PLASMA 300 A NERTAMATIC PLASMA MP PLASMA MANAGER PLASMA + TIG PLC	LD 04 007 LD 04 010 LD 04 020 LE 05 011
350 Amps	BUFFALO	welding intensity regulation thyristor with 1 to 10 Hz pulsation	■ ■	* *	PLASMA BUFFALO TIG BUFFALO	LD 04 016 LC 03 011
500 Amps	NERTINOX TH 500	welding intensity regulation thyristor with 1 to 10 Hz pulsation	■	■	NERTAMATIC PLASMA MP	LD 04 010

* Do not operate the key-hole closure at the end of weld bead.

POWER SOURCES

** Pulsing the PLASMA arc current at two levels (e.g. 100-200 A) produces a very high level of confinement of the energy in the arc (the electromagnetic pinch effect combining with the pneumatic and mechanical confinement imparted by the nozzle). It offers great operator comfort combined with better penetration control and appearance (back of weld).

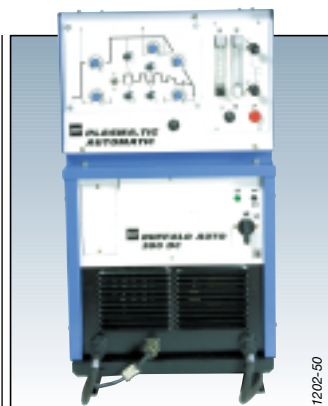

BUFFALO
TIG or plasma installation. Programming and adjustments by potentiometers. Direct current. 350 Amps (100%).



NERTAMATIC 300 TR
This high-technology power source offers a totally regulated welding current facility at frequencies from 1 Hz to 500 Hz**.



NERTINOX TH 500
Thyristor power source. Programmed and adjusted by potentiometers. 500 A DC (100 %).

Welding current (100 %)	30 - 350 A DC 100 %	3 - 300 A DC (± 1 %)	500 A DC 100 %
Pulsed current frequency	10 Hz max (option)	1 - 500 Hz	10 Hz max.
Primary voltage (50 - 60 Hz)	380/400/415 V	220/230/380/400/415/440/500 V	220/380/415 V or 380/440/500 V
Supply current (380 V)	39 A	17.6 A	36 A
Plasma pilot arc	12 A	1 - 25 A adjustable	15 A
Gas circuits	with built-in gyrometers	with built-in gyrometers	gyrometers in the controls
Welding current control	option	option	yes
Process control	yes		no
Dust protection	-	2 interchangeable filters	-
Dimensions (h x w x d)	940 x 517 x 820 mm	1225 x 700 x 790 mm	1320 x 670 x 780 mm
Weight	175 kg	245 kg	450 kg
Cat. Number	TIG : 9121-1049/50/51 ⁽¹⁾ plasma : 9121-1046/47/48 ⁽¹⁾	9114-0556	9114-0532 9114-0533
Insulation	class H	class H	class H
Protection	IP 23	IP 23	IP 23
Torch cooling unit	no	optional for TIG	no

⁽¹⁾ Harness length 10/17/22 m

CONTROLS

■ BUFFALO installation

This installation is dedicated to applications with low evolutions for plasma welding up to 8 mm or TIG up to 3.5 mm. Settings by potentiometers. Numerical display of parameters. Longitudinal or circular welding with limits regarding key hole closure in plasma welding.

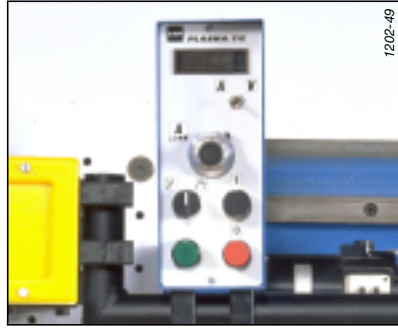

■ Simple Plasma installation

Standard equipment without AVC function for plasma welding of thicknesses up to 8 mm. Intensity adjustment by potentiometers. Numerical display of parameters. Preferred installation for longitudinal welds in seamer. Possible use in circular welds with limits regarding key hole closure in plasma welding. Optional wire feeder device.

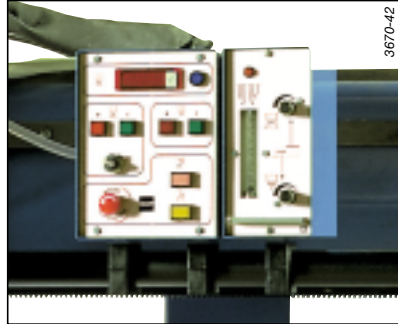

■ PLASMA MP installation

Longitudinal or circular TIG or PLASMA welding equipment with filler metal for all boiler making applications up to 8 mm. Adjustment of all parameters by potentiometers. Numerical display.



■ Plasma manager installation

The 16 bytes multiprocessor MANAGER controller which configuration is programmed depending on chosen peripherals allows complete programming of all functions in more than 100 welding programmes :

- welding current with up and down slopes, frequency and level of pulse current,
- arc voltage (correction of roundness defect of shells),
- filler wire,
- plasma gas flow rate and progressive key hole closure,
- welding speed and circular or longitudinal control of 1 or 2 axis,
- parameters printing possibility.

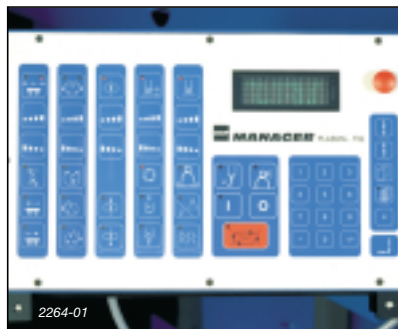

■ NERTAMATIC plasma + TIG installation

For heavy duty work, for large straight or large diameter circular welds. A unique combination of the plasma and TIG processes, controlled by a dedicated, programmable logic controller.



TORCHES

■ SP 120 torch

It's the specific tool of medium power automatic PLASMA welding in boiler making. It allows welding of carbon and stainless steel sheets from 0.3 to 1.5 mm. In association with PLASMA 120 installation SP 120 torch works with a permanent pilot arc, this is of great interest particularly for short sequency assemblies (tacking and discontinuous welding) or for multitorch machines.

Specifications SP 120:

- 120 A at 100 %,
- Tungsten electrode 1.6 - 2.4 - 3.2 mm,
- water cooled nozzle diameters (mm) 1.5 - 2 - 2.5,
- easy replacement and adjustment of the electrode.

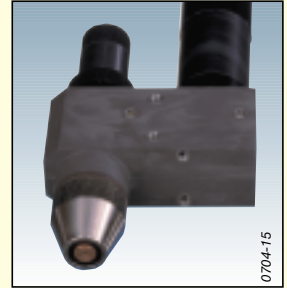

■ SP 6 torch

The heart of your installation, designed as a real mechanical tool, the SP 6 torch guarantees highly accurate reproducibility of the plasma conditions.

The micrometer mechanism for adjusting the electrode allows accurate centering to eliminate imbalances in the plasma jet.

Specifications SP 6:

- 380 A at 100%,
- electrode diameters (mm) from 2.4 to 4.8,
- nozzle main orifice diameters (mm) 1.5 - 2.5 - 3 - 3 CD (convergent/divergent),
- insulated and cooled gas shielding nozzle,
- electrode removable from above without dismantling the nozzle,
- optional gas shielding extender.

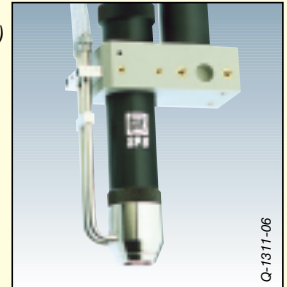

ADD ONS and OPTIONS

■ Torch (or tools) cooling

Plasma equipment is generally delivered with a cooling device allowing torch cooling up to 250 Amps. (REFRISAF GD).

For upper intensities, depending on application and expected duty cycle we can provide an additional cooling device with water refrigeration (FRIOSAF 3).

■ Arc plasma supervision SAF Video System

This fully integrable to the SAF PLASMA installation option allows (with it's high increasing size of the image) a better torch positioning. This option makes easier the operator's work and provides a better quality.



THE SUPPORT STRUCTURE OF THE PLASMA EQUIPMENT

Our specialists will help you in defining the best equipment suitable to your needs, depending upon dimensions of assemblies to be welded as well as work shop organization. Nevertheless, SAF recommend the following configurations that are most commonly utilized :

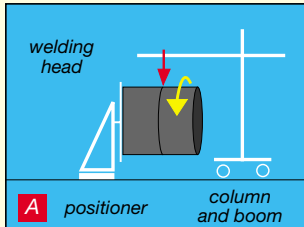

A positioner column and boom
Simple automated system for small tanks, flanges, etc.

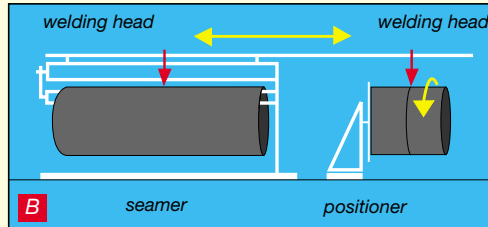

B seamer positioner
No column & boom required, one welding head, small lots.

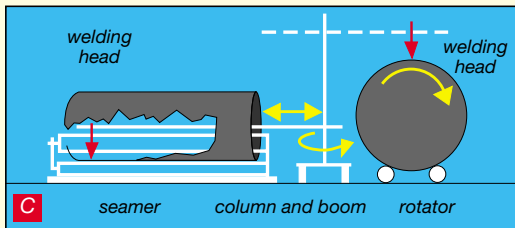

C seamer column and boom rotator
One welding head, small lots. Evolutive to D configuration.

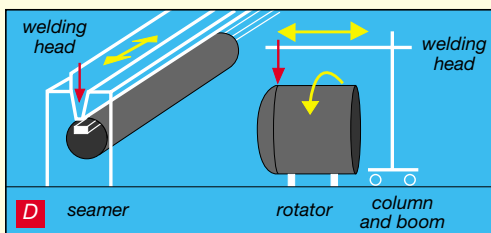

D seamer rotator column and boom
Two welding heads for large lots.

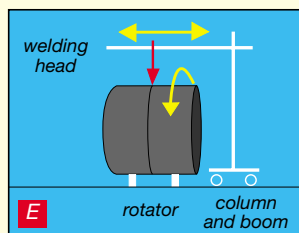

E rotator column and boom
For heavy wall thickness, on pretacked shells. Two heads i.e. PLASMA & SAW possible.

Shell diameter	Configuration	Seamer type	Column & boom MECASAF type
Small diameters	A	None	MFT 15 x 10 or 25 x 23
$\varnothing < 1.5$ m only	B , C or D	Exter	MFT 25 x 23 (if C,D)
$\varnothing > 1.5$ m only	C or D	Inter	MFT 32 x 33 minimum
All diameters	C or D	Exinter	MFT (FFT) 32 x 33 minimum
All diameters thickness > 8 mm	E	None	MFT

COLUMN AND BOOM

For all welding processes the choice of a MECASAF column and boom is synonymous with quality. Besides the simplified column and boom MECASAF 15 x 10, all include :

- double control unit,
- fast advance without affecting welding speed,
- arm, carriage or bending gear movement preselection,
- anti-drop and travel limit devices.

Available stroke length :
 • vertical : 1.5 to 6.2 m,
 • horizontal : 1.0 to 4.2 m
 (on request up to 6.2 m).

ROTATOR

From our large range, SAF recommends the use of our VIROSAF :

- mono or twin motorized roller with tachometre,
 - infinitely variable roller separation.
- All our models are fitted with remote speed control.

SEAMER

For internal (inter) or external (exter) or both (exinter) automatic welding of flat or rounded sheets, SAF provides a complete range of quality seamers suitable for all welding processes.

- The main characteristics of SAF seamers are :
- excellent visibility,
 - high pressure applied by jaws (2 x 3 tons per m),
 - quick adjustment by two rows of stainless steel jaws,
 - the rear framework is open enabling «off-bench» welding.

DISTRIBUTOR'S STAMP